

**FAMILY
NEST**

FACCO
POULTRY EQUIPMENT

The expertise in the designing and manufacturing family nests is focus for Facco from more than 40 years, thanks to the great knowledge of the hens, planning and managing farms in over 70 countries.

Facco installed a Family Nest system in FICO, the largest agri-food park in the world. The park works to enhance agricultural, farming and Made in Italy excellences, and the Facco systems perfectly embody the efficient, safe and tested type of egg production closest to homemade and traditional products, thanks precisely to its protection of the hens.



The nest is the **centre of the hen's life** and is crucial for its **well-being**: it is the most complex and delicate structure in terms of management, given that it requires **maximum attention to detail during the design phase**, for it to integrate perfectly within the system.

The hen goes inside the nest, lays the egg which is collected in real time, and is then delicately expelled. Good design of a nest requires knowledge of the hen's characteristics, habits and needs, regardless of the geographic location, as well as the capacity to create a synergy between structure and technology that allows for best use of all available resources.



MATERIALS

The study and evolution of materials over the years has allowed us to develop a strong specialization and to create important synergies between high technology and typically Italian capacity and handicraft, universally appreciated and acknowledged. Our nests are available in high quality, resistant, waterproof, eco-friendly and hygienically advanced materials.

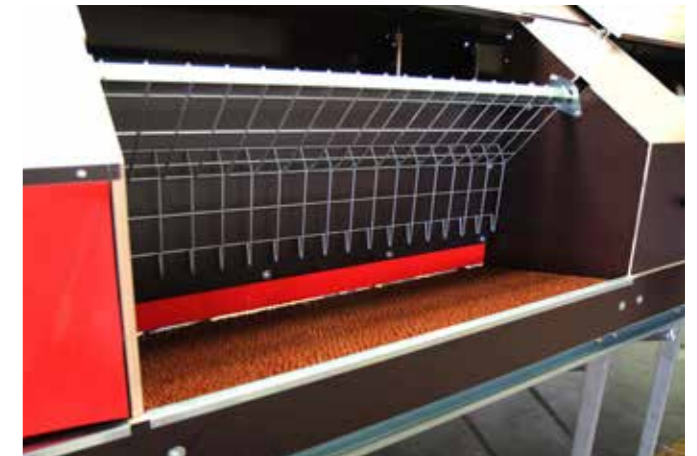
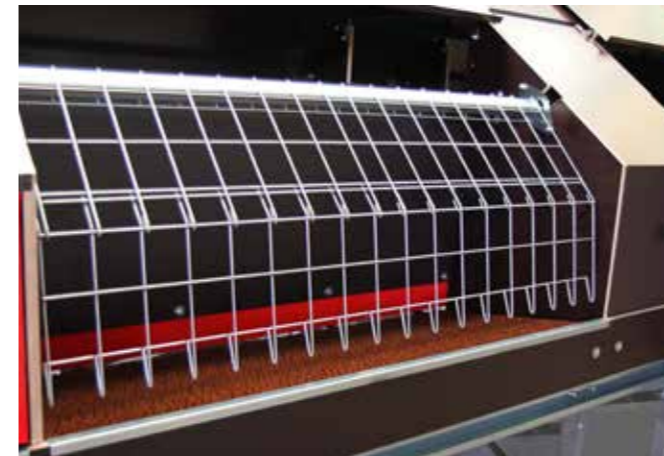

Internal partitions and many other components of the nest are developed in phenolic adhesive birch plywood, a material which is perfectly suited for end-of-cycle washing and disinfection operations. The load-bearing structure in galvanized steel is supported by stainless steel legs and feet; all metal components are open-profile preventing the growth of bacteria.

The nest floor is a soft AstroTurf mat, with a conformation that prevent the accumulation of dust, feathers or manure, offers a pleasant sensation for the hen's feet and favours the air circulation. Therefore, it creates a clean and comfortable area for the laying of eggs.

RELAX AREA

The nests, delimited by the sides and by the plastic curtains, are a relaxed space that is separated from adjacent areas. The structure allows for prompt egg collection. The expulsion system located at the centre of the nest is easy to access for installation and maintenance purposes. The slow movement of the expulsion panels gently accompanies the animals out of the nest during night hours, eliminating problems related to hatching or overcrowding.

- **Safe**
- **Long-lasting**
- **Quiet**

Our Family Nest is highly flexible, as it can be developed on one or two floors according to the client's objectives. The structure design facilitates access to the second tier, therefore guaranteeing maximum use of the available space. Furthermore, the nests can be positioned centrally or against the wall.

- **Accessibility**

- **Flexibility**

- **Maximum use of available space**

The Facco system, which can be programmed automatically, reproduces the typical day in a hen's life and a correct routine.



EGG COLLECTION

The slope floor of the Family Nest allows the eggs to gently slide towards the collection belt, at the centre of the nest.

The perforated polypropylene belt keeps the eggs clean and in balance: this means they reach their destination in stable conditions and rapid times, minimizing breakage issues. Speed can be adjusted according to the quantity of eggs, facilitating collection by the operator.

The egg collection system can be done by placing a motorized table at the beginning of the row or through the well known Facco Niagara.

The Facco **NIAGARA – The original** – egg collection system seamlessly combines collection speed, durability, reliability, low consumption levels, low and simple maintenance and above all a delicate processing of the eggs, an essential feature for minimizing micro-fractures.

Each movement has been designed with attention and expertise, translating into one of the most-imitated designs in the field.



FEEDING SYSTEM

The flat chain feeding system, introduced by Facco during the 1970s, is ideal for feed distribution in commercial layer house hen laying and farming systems.

It is **safe**, **reliable** and **easy to install**. Its various speed options (12-18-36mt/min) allow it to adapt to all types of production plants, guaranteeing high feed distribution performances.

The circuits can be supported by adjustable feet, anchored to the ceiling or lean on specific supports which sustain the perches. This is a key system for the farming of commercial hens. The high flexibility of this system can meet any variety of needs. The hoppers can vary in capacity, thus feeding multiple circuits simultaneously.



DRINKING SYSTEM

The FACCO drip troughs are **functional** and **precise**, guarantee waste-free high water supply performances and are ideal for all types of animals. Furthermore, our vast range of products allows for customization of the number of nipples in relation to the number of animals present in the structure.



Our drinking system lines are completed by: pressure regulators, a discharge unit with integrated cleaning system, filters, medication dosing systems, litre-counters and lifting accessories which allow the operator to raise the equipment in relation to the growth of the animal and for end-of-cycle cleaning operations.

TECHNICAL FEATURES FAMILY NEST 1 TIER

1 TIER MODULE	1 Side Nest	1 Central Nest
LENGTH	2,4	2,4
NUMBER OF HOLES	2	4
NEST SURFACE (mq)	1,19	2,37
BELT WIDTH (mm)	250	500

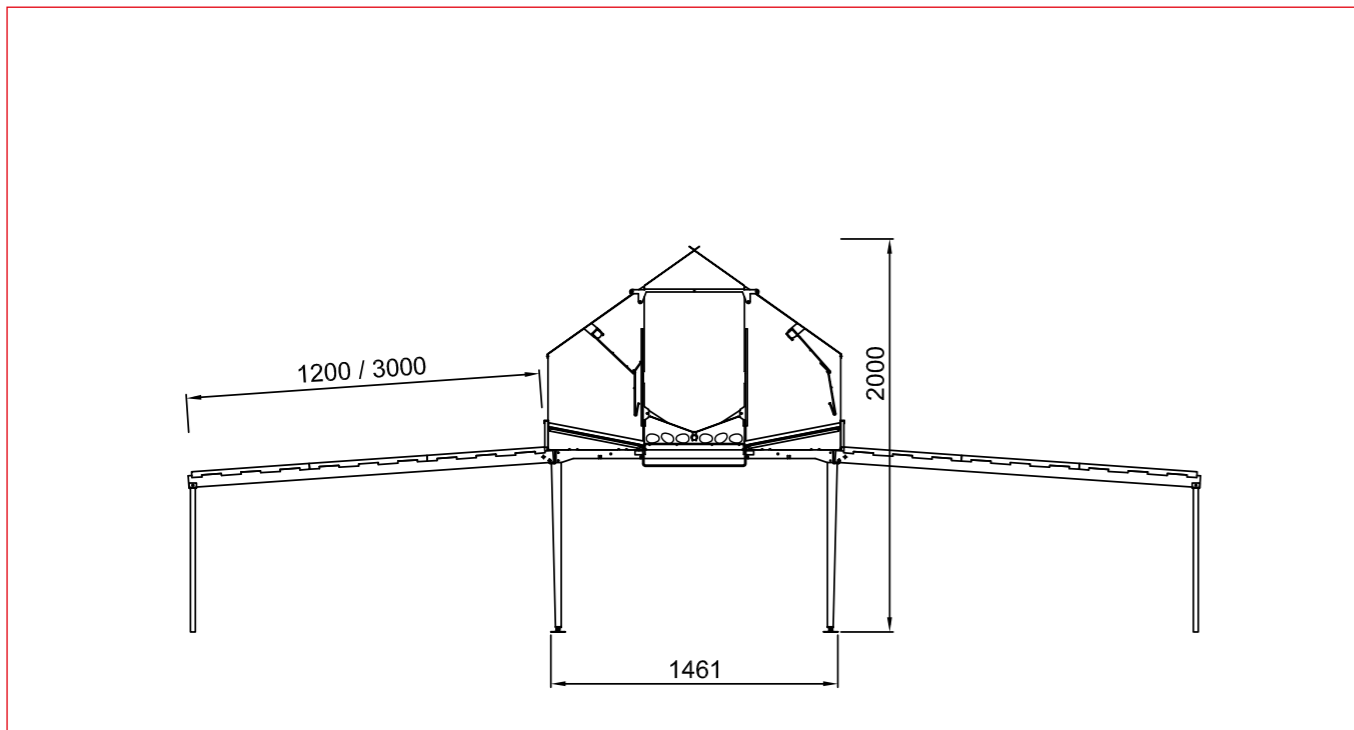
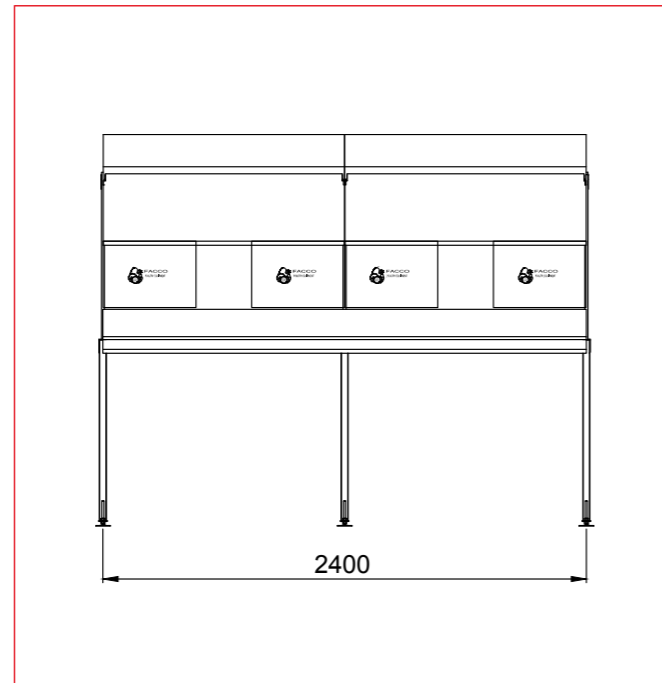
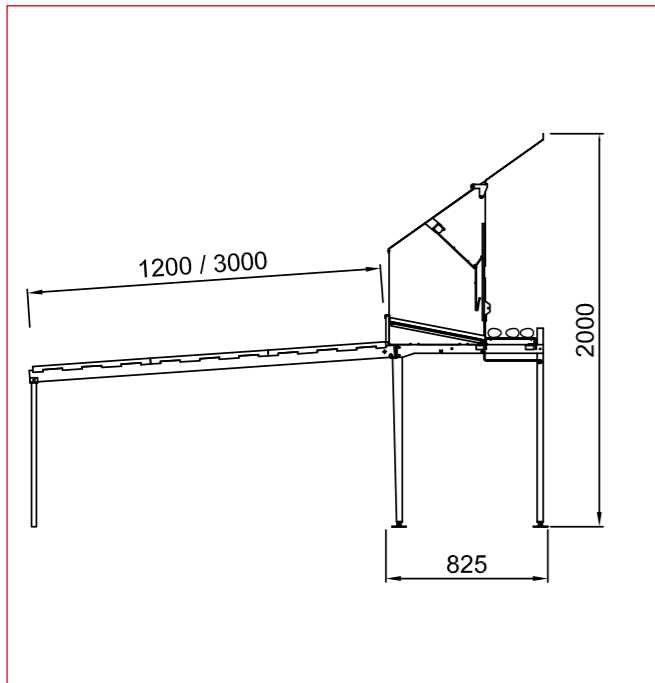

TECHNICAL FEATURES FAMILY NEST 2 TIERS

FAMILY NEST	2 Side Nests	2 Central Nests
LENGTH	2,4	2,4
NUMBER OF HOLES	4	8
NEST SURFACE (mq)	2,37	4,74
BELT WIDTH (mm)	250	500

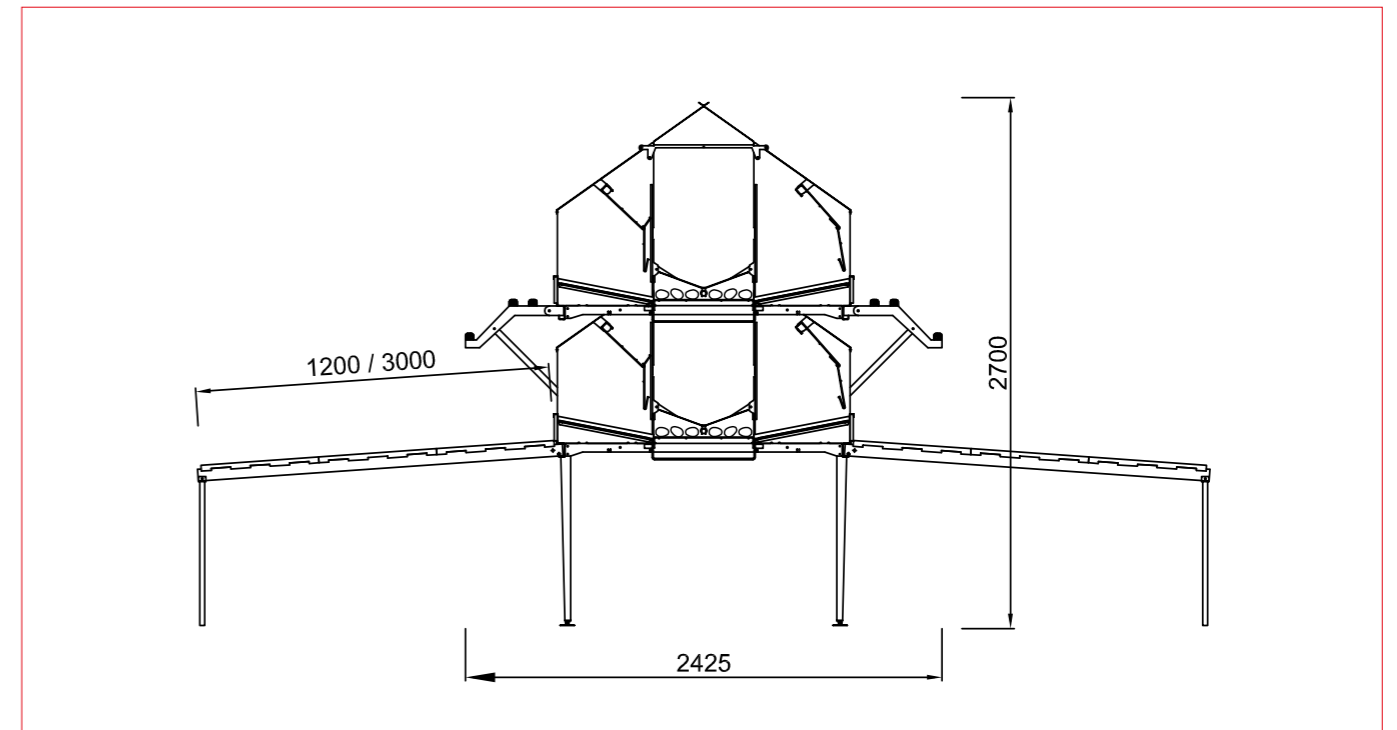
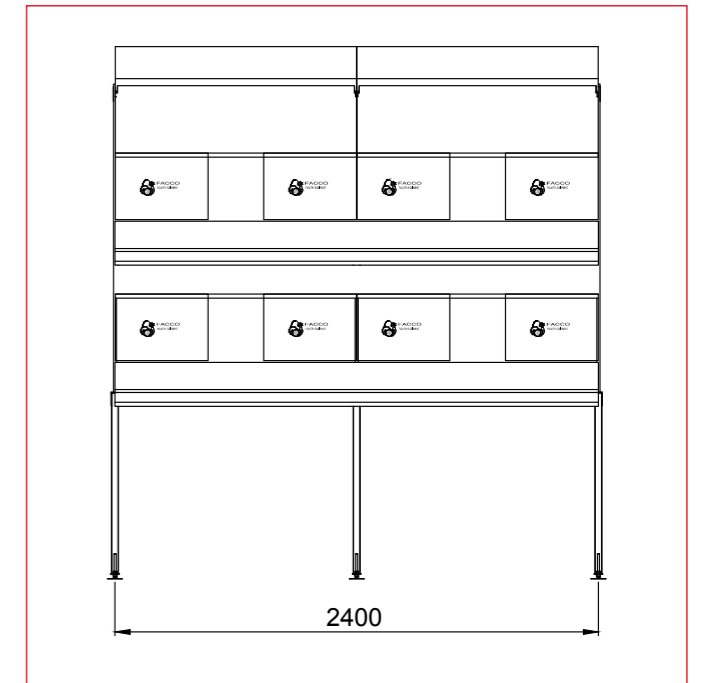
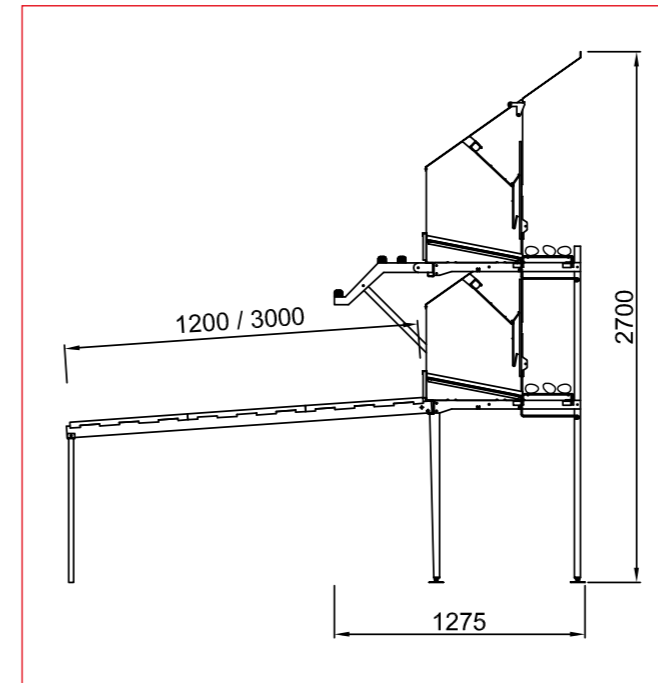



FACCO

POULTRY EQUIPMENT

OFFICINE FACCO & C. S.p.A.

Via Venezia, 30
35010 Marsango (PD) Italy

Tel. +39 049 9698111

Fax +39 049 9630605

facco@facco.net

www.facco.net

